



The chocolate wall fountain will appeal to the most innovative venues on the market as it offers the possibility of obtaining a sensational atmosphere creating, on an area of about 2 square meters, a waterfall of continuous flowing chocolate that, in addition to the visual effect emphasized with LED lighting, emanates inviting aromas of chocolate inside the room.

Designed and built for those who wish to possess within their premises a particular and unusual piece of indisputable effect.

The machine is delivered 'bare', i.e. without a wooden frame around the edges, for subsequent insertion in the furnishings of the hosting premises.

Mechanical characteristics

Overall dimensions
Empty weight
Material in contact with food
Tank capacity

[mm] (LxWxH) 1030x620x2640
[kg] 280
inox AISI 304 L
[kg] 24

Electrical characteristics

Total installed power
Supply voltage
Number of phases
Frequency
Auxiliary voltage
Enclosure degree of protection
Connection type: industrial plug

[kW] 3,5
[VAC] 400
3
[Hz] 50 / 60
-
IP65
16A - 5 poles

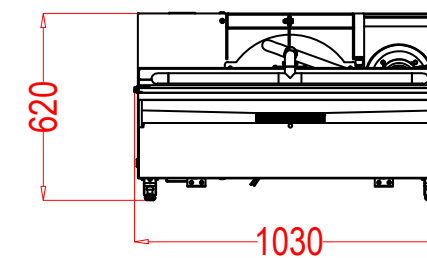
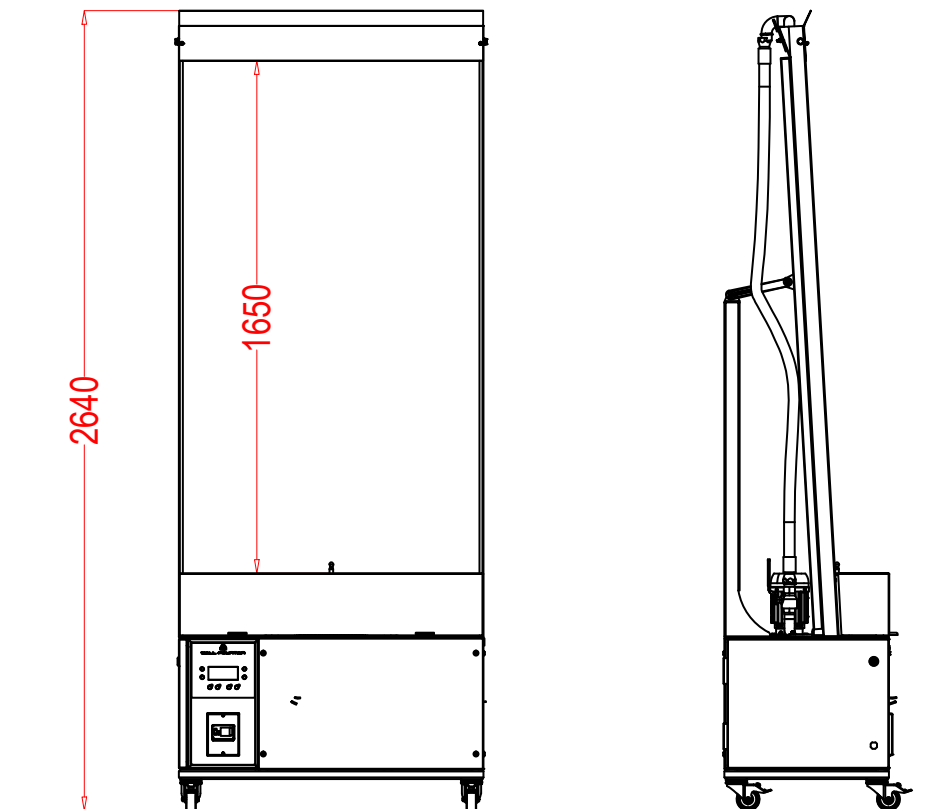

SELMI chocolate machinery

www.selmi-group.it
info@selmi-group.it

Tel: +39 0172 479 273
Fax: +39 0172 477 814

Via Langhe 25,
12042 Pollenzo (CN)



* optional
These data may change based on the installation conditions requested in the contract phase. For the correct data, refer to the plate located inside the electrical panel.